

Model 1159 Remote Diaphragm Seals

with Model 1152, Model 1153 Series B, D and F, and Model 1154
Alphaline® Nuclear Pressure Transmitters



ROSEMOUNT® NUCLEAR

FISHER-ROSEMOUNT® Managing The Process Better™

Qualified per IEEE Std 323-1974 and IEEE Std 344-1975:

- 1.0×10^8 rads TID gamma radiation
- 7 g ZPA seismic
- 420 °F (215 °C) steam/temperature profile

Other Benefits Include:

- Ranges up to 1,000 psi
- Low-volume design, reduced temperature effects
- Designed for class IE safety-related applications

INTRODUCTION

Rosemount Nuclear Instruments, Inc. has combined nuclear-qualified pressure transmitters with threaded remote diaphragm seals to provide the nuclear power industry with a proven design for safety-related applications. Model 1159 Remote Diaphragm Seals were qualified per IEEE Std 323-1974 and IEEE Std 344-1975 to the following levels: 1.0×10^8 rads TID gamma radiation, seismic testing to a generic required response spectrum (RRS), and LOCA conditions to 420 °F (215.6 °C).

Rosemount offers the Model 1159 Threaded Remote Diaphragm Seals on Model 1152, Model 1153 Series B, D, and F, and Model 1154 Alphaline® Nuclear Differential Pressure Transmitters to encompass both boiling water and pressurized water reactor applications. Rosemount nuclear pressure transmitters, combined with the Model 1159 Remote Diaphragm Seals, reliably and accurately measure process pressure or liquid level while preventing the process fluid from contacting the transmitter diaphragm.

OPERATION

Process pressure sensed by the remote seal diaphragm is transmitted through a filled capillary system to the transmitter's isolating diaphragm. The transmitted pressure displaces the sensing diaphragm in the transmitter's δ -Cell™ creating a differential capacitance between the sensing diaphragm and the capacitor plates. The differential capacitance is converted electronically to a 2-wire, 4–20 mA dc signal.



Fisher-Rosemount satisfies all obligations coming from legislation to harmonize product requirements in the European Union.

SPECIFICATIONS

Nuclear Specifications

Transmitter

Refer to appropriate product data sheets for transmitter specifications.

Remote Seal and Capillary

Qualified per IEEE Std 323-1974 and IEEE Std 344-1975, as stated in Rosemount Report D8300151

Radiation

Exposed to 1.0×10^8 rads, total integrated dosage of gamma radiation

Seismic

Tested to a generic required response spectrum (RRS)

Steam Pressure/Temperature (LOCA)

Exposure to steam with chemical spray at the following temperatures and pressures:

420 °F (215.6 °C), 50 psig for 3 minutes

350 °F (176.7 °C), 110 psig for 7 minutes

320 °F (160.0 °C), 73 psig for 8 hours

265 °F (129.4 °C), 24 psig for 56 hours

Static pressure is required on process connections when temperature exceeds 180 °F (82.2 °C).

Quality Assurance Program

In accordance with NQA-1, 10CFR50 Appendix B, and ISO 9001

Traceability

In accordance with NQA-1 and 10CFR 50 Appendix B; chemical and physical material certification of pressure retaining parts

Nuclear Cleaning

To 1 ppm maximum chloride content

Hydrostatic Testing

To 150% of maximum working pressure or 2000 psi (13.8 MPa), whichever is greater

Qualified Life

Remote seal qualified life is equivalent to transmitter qualified life (see the appropriate product data sheet for transmitter qualified life).

Rosemount, the Rosemount logotype, and Alphaline are registered trademarks and δ -Cell is a trademark of Rosemount Inc. Inconel is a registered trademark of International Nickel Co. Swagelok is a registered trademark of the Crawford Fitting Co. Helicoflex is a trademark of Helicoflex Co. D.C. is a registered trademark of Dow Corning Corp.

Cover photo: 1159-001AB

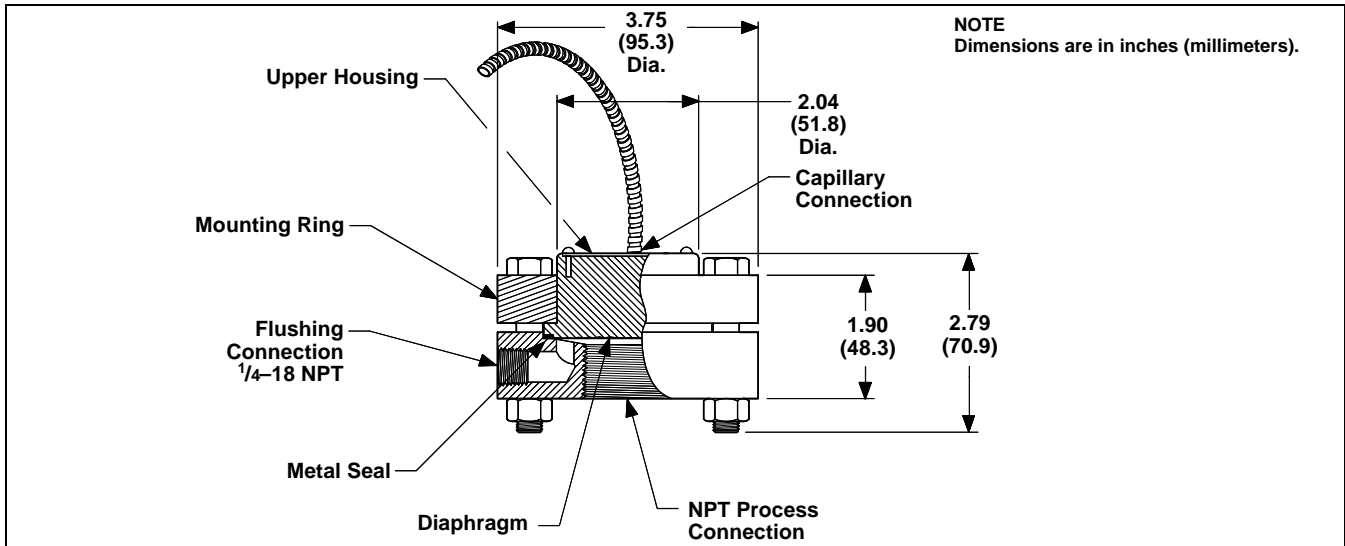

FIGURE 1. Model 1159 Remote Diaphragm Threaded Seal.

1159-1159A23A

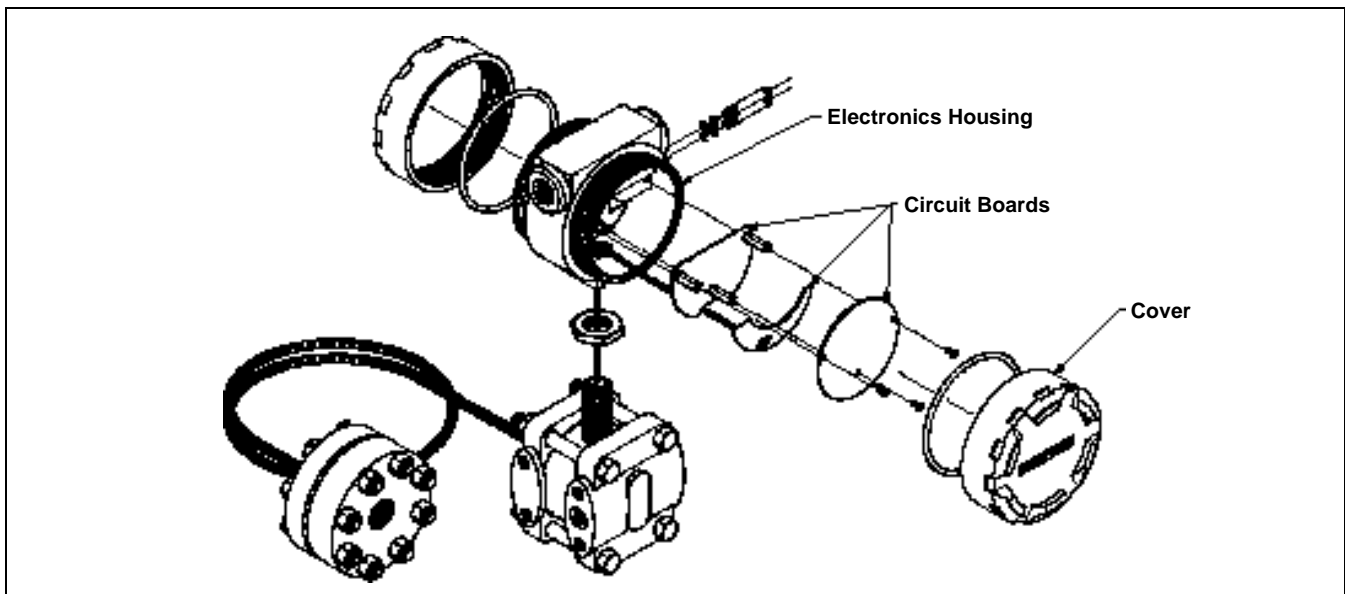

FIGURE 2. Typical Model 1153 Series B Differential Pressure Transmitter with Remote Diaphragm Seal Assembly.

1159-1159A02A

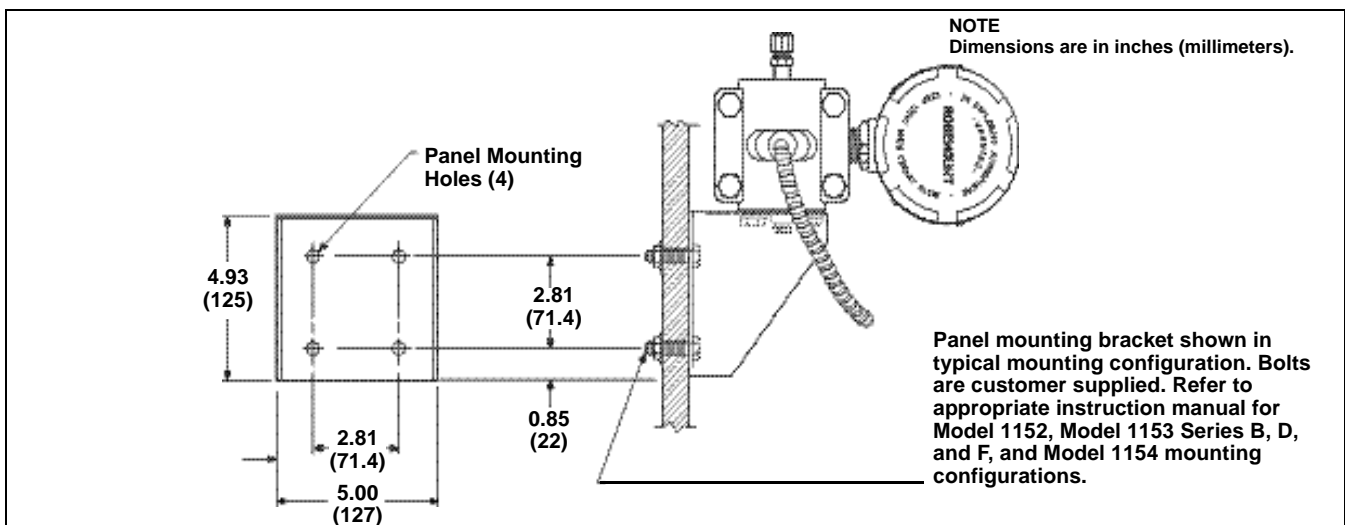

FIGURE 3. Typical Model 1154 with Remote Diaphragm Seal Assembly Mounting Configuration.

1159-1159A99A

Functional Specifications

Service

Liquid

Pressure Limits

0–2000 psig (Models 1152DP, 1153DB, DD, DF and 1154DP)

0–upper range limit (Model 1152GP)

Ranges

Range Code	Pressure Ranges
3	0–5 to 0–30 inH ₂ O (0–1.24 to 0–7.46 kPa)
4	0–25 to 0–150 inH ₂ O (0–6.22 to 0–37.3 kPa)
5	0–125 to 0–750 inH ₂ O (0–31.08 to 0–186.4 kPa)
6	0–17 to 0–100 psi (0–0.12 to 0–0.69 MPa)
7	0–50 to 0–300 psi (0–0.34 to 0–2.07 MPa)
8	0–170 to 0–1,000 psi (0–1.17 to 0–6.89 MPa)

Transmitter Output

4–20 mA dc

Humidity Limits

0–100% relative humidity

Temperature Limits

Transmitter:

Refer to the appropriate data sheet for transmitter temperature limits.

Seal and Capillary:

40 to 180 °F (4.4 to 82.2 °C)

For operation at temperatures above 180 °F, apply a static pressure to the remote seal to prevent the fill fluid from boiling. Refer to steam tables for appropriate pressures.

Storage Limits:

40 to 180 °F (4.4 to 82.2 °C)

Specific Gravity of Fill Fluid

1.0

Performance Specifications

Transmitter

Refer to appropriate product data sheet for transmitter specifications.

Seal and Capillary Temperature Effect (Typical)

1-Seal System:

Zero Error:

±(1.3 inH₂O/100 °F for first 5 ft of capillary + 0.5 inH₂O/100 °F for each additional 5 ft of capillary)

Full-Scale Error:

±(1.5 inH₂O/100 °F for first 5 ft of capillary + 0.6 inH₂O/100 °F for each additional 5 ft of capillary)

2-Seal System:

Zero error:

±(1.1 inH₂O/100 °F for first 5 ft of capillary + 0.4 inH₂O/100 °F for each additional 5 ft of capillary)

Full-scale error:

±(1.3 inH₂O/100 °F for first 5 ft of capillary + 0.5 inH₂O/100 °F for each additional 5 ft of capillary)

Response Time

Range 4:

0.3 seconds per 5 ft of capillary

Range 5–8:

0.1 seconds per 5 ft of capillary

The effect is in addition to the time response of the transmitter alone.

Mounting Position Effect

The mounting position effect is dependent on the elevation of the seal(s) with respect to the transmitter.

Physical Specifications

Seal Weight

5 lb

Capillary Weight

1 oz/ft of capillary

Seal and Capillary Fill Fluid

Distilled water

Flushing Connection

¼–18 NPT

Process Connection

¼, ½, or 1 NPT, or a 1-in. socket weld

Materials of Construction

Seal:

Isolating diaphragm: 316L SST

Upper housing: 316 SST

Lower housing: 316 SST

Bolts: plated alloy steel

Metal seal: silver with Inconel® 600 and Inconel 750X (Helicoflex™)

Mounting ring: 316 SST

Capillary:

Capillary tubing: 316 SST, 0.028-in. ID

Protective armored sleeving: 304 SST

Accessories:

Capillary clamps (optional): 316 SST (P/N 01159-0301-0001)

MODEL 1152 ORDERING INFORMATION

Model	Product Description			
1152	Alphaline Pressure Transmitters for Nuclear Applications			
Code	Pressure Measurement			
DP GP	Differential Pressure, 2,000 psig Static Pressure Rating Gage Pressure			
Code	Pressure Range			
3	0–5 to 0–30 inH ₂ O (0–1.24 to 0–7.46 kPa)			
4	0–25 to 0–150 inH ₂ O (0–6.22 to 0–37.3 kPa)			
5	0–125 to 0–750 inH ₂ O (0–31.08 to 0–186.4 kPa)			
6	0–17 to 0–100 psi (0–0.12 to 0–0.69 MPa)			
7	0–50 to 0–300 psi (0–0.35 to 0–2.07 MPa)			
8	0–170 to 0–1,000 psi (0–1.15 to 0–6.89 MPa)			
Code	Output			
N ⁽¹⁾	4–20 mA dc with Adjustable Damping			
MATERIALS OF CONSTRUCTION				
Code	Flanges	Drain/Vent Valves	Isolating Diaphragms	Electronics Housing/ Covers
22	316 SST	316 SST	316 SST	Aluminum
92	316 SST	316 SST	316 SST	Austenitic SST
Code	T-Options			
T1808 ⁽²⁾	One Seal with one 1/4–18 NPT and one Drain/Vent Valve			
T1809	Two Seals			
Code	Options			
PB	Panel Mounting Bracket			
PM	2 in. Pipe Mounting Bracket			
Typical Model Number: 1152 DP 4 N 22 T1808 PB				

(1) For 10–50 mA output, the “N” is replaced with “L.” For example: 1152DP5L22T1808PB. Transmitters with Output Code L have seismic qualification only.

(2) Unless otherwise noted, flange option T1808 will have the remote seal installed on the high side.

MODEL 1153 SERIES B AND D ORDERING INFORMATION

Model	Product Description
1153	Alphaline Pressure Transmitters for Nuclear Applications
Code	Pressure Measurement
D	Differential Pressure, 2,000 psig Static Pressure Rating
Code	Series
B D	Aluminum Housing, qualified per IEEE Std 323-1974 and IEEE Std 344-1975 SST Housing, qualified per IEEE Std 323-1974 and IEEE Std 344-1975
Code	Pressure Range
4	0–25 to 0–150 inH ₂ O (0–6.22 to 0–37.3 kPa)
5	0–125 to 0–750 inH ₂ O (0–31.08 to 0–186.4 kPa)
6	0–17 to 0–100 psi (0–0.12 to 0–0.69 MPa)
7	0–50 to 0–300 psi (0–0.35 to 0–2.07 MPa)
8	0–170 to 0–1,000 psi (0–1.15 to 0–6.89 MPa)
Code	Output
P R	Standard 4–20 mA dc Improved Radiation Performance 4–20 mA dc
Code	Flange Option
D ⁽²⁾ E ⁽¹⁾⁽²⁾ F ⁽¹⁾⁽²⁾ G	One Seal with Swagelok™ and Drain/Vent Valve One Seal with 1/4-in. NPT and Drain/Vent Valve One Seal with 1/4-in. NPT/1/4-in. NPT Two Seals
Typical Model Number 1153 D D 4 P E	

(1) The customer assumes the responsibility for qualifying the process interfaces on this option.

(2) Unless otherwise noted, flange options D, E, and F will have the remote seal installed on the high side.

MODEL 1153 SERIES F ORDERING INFORMATION

Model	Description
1153	Alphaline Pressure Transmitters for Nuclear Applications
Code	Pressure Measurement
D	Differential Pressure, 2,000 psig Static Pressure Rating
Code	Series
F	Painted aluminum housing; qualified per IEEE Std 323-1974 and IEEE Std 344-1975
Code	Pressure Ranges
4	0–25 to 0–150 inH ₂ O (0–6.22 to 0–37.3 kPa)
5	0–125 to 0–750 inH ₂ O (0–31.08 to 0–186.4 kPa)
6	0–17 to 0–100 psi (0–0.12 to 0–0.69 MPa)
7	0–50 to 0–300 psi (0–0.35 to 0–2.07 MPa)
8	0–170 to 0–1,000 psi (0–1.15 to 0–6.89 MPa)
Code	Output
T	Standard 10–50 mA
Code	Flange Option
D ⁽²⁾ E ⁽¹⁾⁽²⁾ F ⁽¹⁾⁽²⁾ G	One Seal with Swagelok and Drain/Vent Valve One Seal with 1/4-in. NPT and Drain/Vent Valve One Seal with 1/4-in. NPT/1/4-in. NPT Two Seals
Typical Model Number 1153 D F 4 T E	

(1) The customer assumes the responsibility for qualifying the process interfaces on this option.

(2) Unless otherwise noted, flange options D, E, and F will have the remote seal installed on the high side.

MODEL 1154 ORDERING INFORMATION

Model	Product Description
1154	Alphaline Pressure Transmitters for Nuclear Applications
Code	Pressure Measurement
DP	Differential Pressure, 2,000 psig Static Pressure Rating
Code	Pressure Range
4	0–25 to 0–150 inH ₂ O (0–6.22 to 0–37.3 kPa)
5	0–125 to 0–750 inH ₂ O (0–31.08 to 0–186.4 kPa)
6	0–17 to 0–100 psi (0–0.12 to 0–0.69 MPa)
7	0–50 to 0–300 psi (0–0.35 to 0–2.07 MPa)
8	0–170 to 0–1,000 psi (0–1.15 to 0–6.89 MPa)
Code	Output
R	Standard 4–20 mA dc
Code	Flange Option
D ⁽²⁾	One Seal with <i>Swagelok</i> and Drain/Vent Valve
E ⁽¹⁾⁽²⁾	One Seal with 1/4-in. NPT and Drain/Vent Valve
F ⁽¹⁾⁽²⁾	One Seal with 1/4-in. NPT/1/4 NPT
G	Two Seals
Typical Model Number 1154 DP 4 R E	

(1) The customer assumes the responsibility for qualifying the process interfaces on this option.

(2) Unless otherwise noted, flange options D, E, and F will have the remote seal installed on the high side.

MODEL 1159 ORDERING INFORMATION

Model	Product Description
1159	Remote Seal Assembly
Code	Threaded Remote Seal
A	1/4-in. NPT Process Connection
B	1/2-in. NPT Process Connection
C	1-in. NPT Process Connection
D ⁽¹⁾	1-in. Socket Weld Process Connection
Code	Capillary ⁽²⁾
05	5 ft
10	10 ft
15	15 ft
20	20 ft
25	25 ft
30	30 ft
35	35 ft
40	40 ft
45	45 ft
50	50 ft
55	55 ft
60	60 ft
Code	Fill Fluid
A ⁽³⁾	Distilled Water
Code	Special Options
S0111	Remote Seal for Range Code 3 Transmitter (consult factory before ordering)
Typical Model Number 1159 C 10 A	

(1) The customer assumes the responsibility for qualifying the process interfaces on this option.

(2) Model 1152 Range Code 3 is limited to capillary lengths up to 25 ft.

(3) The Model 1159 is available with D.C.[®] 704 silicone oil fill. It is also available with D.C. 200 silicone oil fill, seismic qualification only. Capillary lengths of 15 ft or less are recommended for silicone oil fill. Specifications may differ with fill fluid option. Contact Rosemount Nuclear Instruments, Inc. for details.

Rosemount Nuclear Instruments, Inc.

12001 Technology Drive
Eden Prairie, MN 55344
Tel (612) 828-8252
Telex 4310012
Fax (612) 828-8280
© 1999 Rosemount Nuclear Instruments, Inc.
<http://www.rosemount.com>



00813-0100-4504 Rev. AB

Model 1152 Alkaline Pressure Transmitter for Nuclear Applications may be protected by one or more of the following U.S. Patent Numbers: 3,618,390; 3,646,538; 3,793,885; 3,800,413; 3,975,719 and Re. 30,603. Canada patented (Brevete) 1974, 1975, 1976, and 1979. May depend on model. Other foreign patents issued and pending.

Model 1153 Series B Alkaline Pressure Transmitters may be protected by one or more of the following U.S. Pat. Nos. 3,618,390; 3,646,538; 3,800,413; 3,975,719; and Re. 30,603. May depend on model. Other foreign patents issued and pending.

Model 1153 Series D Alkaline Pressure Transmitter may be protected by one or more of the following U.S. Patent Numbers: 3,975,719; and Re. 30,603. May depend on model. Other foreign patents issued and pending.

Model 1153 Series F Alkaline Pressure Transmitter may be protected by U.S. Patent Number: 3,975,719. May depend on model. Other foreign patents issued and pending.

Model 1154 Alkaline Pressure Transmitter for Nuclear Applications may be protected by one or more of the following U.S. Patent Numbers: 3,975,719. May depend on model. Other foreign patents issued and pending.

ROSEMOUNT[®] NUCLEAR

FISHER-ROSEMOUNT[™] Managing The Process Better[™]