

Subject to change without notice

VALVE AUTOMATION SYSTEMS

W W W . e l o - m a t i c . c o m

All rights reserved

1.101.33

March '05

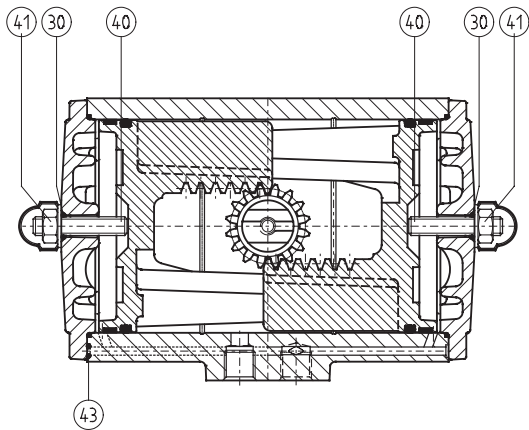
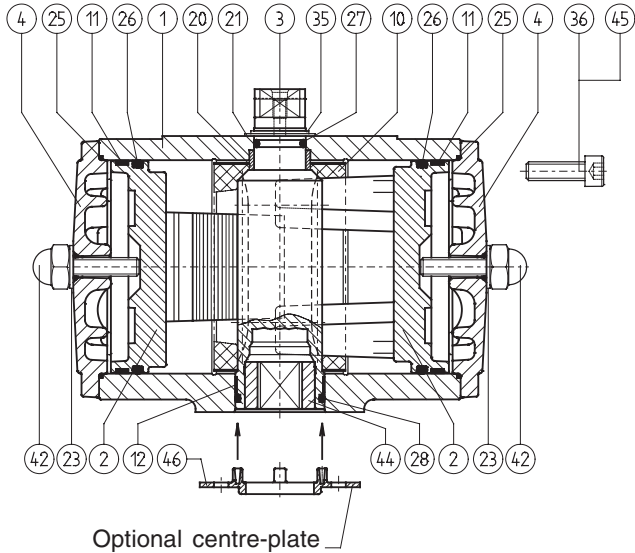

DOUBLE ACTING ED

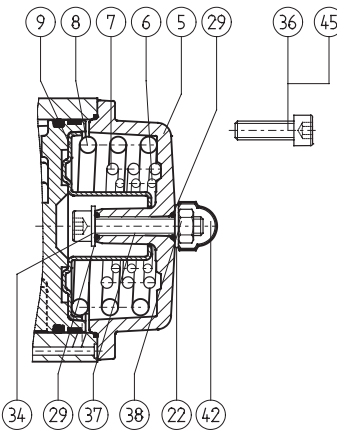

SINGLE ACTING ES

Parts			Materials		Executions		
Nr.	Description	Qty.	Description	Specification	Std	S.S. Shaft	CSR
1	Body	1	Aluminium Alloy	GAISI10Mg, DIN 1725/2	-	-	5
2	Piston	2	Aluminium Alloy	GAISI 7Mg, DIN 1725/2	-	-	-
3	Drive Shaft	1	Aluminium Alloy	AlZnMgCu1.5, DIN 1725/1	1	6	6
4	End Cap ED	2	Aluminium Alloy	GDAISI9Cu3, DIN 1725/2	-	-	5
5	End Cap ES	2	Aluminium Alloy	GDAISI9Cu3, DIN 1725/2	-	-	5
6	Spring- inner	2	Carbon Spring Steel	Class C, DIN17223	2	2	2
7	Spring- mid	2	Carbon Spring Steel	Class C, DIN17223	2	2	2
8	Spring- outer	2	Carbon Spring Steel	Class C, DIN17223	2	2	2
9	Spring Holder	2	Steel	RSt 14-03, DIN 1623	3	3	3
10	* Guide Band	1	Nylatron	PA6.6 + MoS2	-	-	-
11	* Guide Band	2	PTFE, Carbon filled	PTFE + 25% C	-	-	-
12	* Bearing Bush	1	Nylatron	PA6.6 + MoS2	-	-	-
20	* Bearing Bush	1	Delrin	POM	-	-	-
21	* O-ring	1	Nitrile Rubber	Buna N	-	-	-
22	* Washer ES	2	Nylon	PA6	-	-	-
23	* Washer ED	2	Nylon	PA6	-	-	-
25	* O-ring	2	Nitrile Rubber	Buna N	-	-	-
26	* O-ring	2	Nitrile Rubber	Buna N	-	-	-
27	* Washer	1	ZEDEX 100 K	-	-	-	-
28	* O-ring	1	Nitrile Rubber	Buna N	-	-	-
29	* O-ring	4	Nitrile Rubber	Buna N	-	-	-
30	* O-ring	2	Nitrile Rubber	Buna N	-	-	-
34	Washer ES	2	Steel	C35	3	3	3
35	* Spring Clip	1	Carbon Spring Steel	C45, DIN 17200	2	7	7
36	End Cap Bolt ED/ES	8	Stainless Steel	AISI 304	-	-	-
37	Limit Stop Bolt ES	2	Stainless Steel	AISI 304	-	-	-
38	Nut	2	Stainless Steel	AISI 304	-	-	-
40	Limit Stop Bolt ED	2	Stainless Steel	AISI 304	-	-	-
41	Nut	2	Stainless Steel	AISI 304	-	-	-
42	Nut Cover	2	Polyethylene	PE	-	-	-
43	* O-ring	2	Nitrile Rubber	Buna N	-	-	-
44	Insert	1	Aluminium Alloy	AlMgSi1	4	9	4
45	Threaded insert	8	Steel	9S MnPb28K	3	3	3
46	Centre-plate	1	Nylon, Glassfilled	PA6 + 25% Glass	-	-	-

* Recommended spare parts (contained in Repair kits)

Notes

- 1 : Hard anodized aluminium alloy: AlZnMgCu1.5, DIN 1725/1
- 2 : Deltatone Coating.
- 3 : Anodized.
- 4 : Zinc plated and passivated.
- 5 : CSR Coating (see 4.204.02).
- 6 : Stainless Steel Sandvic 1802, SS2382.
- 7 : Stainless Steel X35CrM017.
- 8 : No insert, adaptor square direct in pin-ion.

Finish:

- Standard : Polyester non-TGIC based powder coating (see data sheet 4.204.01)
- CSR : CSR Coating (see data sheet 4.204.02)

CONSTRUCTION, PARTS AND MATERIALS E-SERIE ACTUATORS

E