

Data sheet

Sheet No.: 5.204 Rev. A
Date: November 2009

EL ACTUATOR WITH SPEED CONTROL TIMER - AC (Kit option)

SC

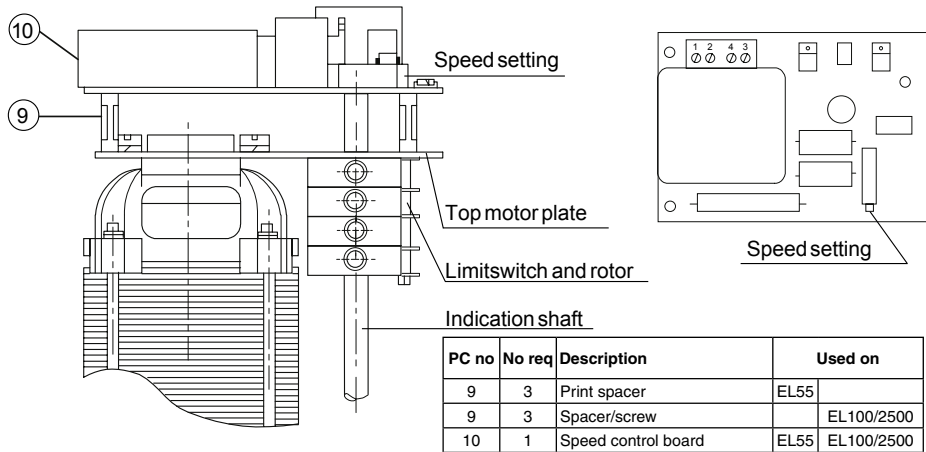

PC no	No req	Description	Used on
9	3	Print spacer	EL55
9	3	Spacer/screw	EL100/2500
10	1	Speed control board	EL55 EL100/2500

Description

This electric actuator variation has the addition of an electronic card, this is provided complete with a dual voltage (AC.) power supply, a trimmer for motor pulse adjustments and a triac for motor switching.

The circuit provides a timed ON/OFF switching cycle. The ON pulse is fixed at 0.5 sec and the OFF pulse is adjustable via the trimmer.

This adjustment is easily carried out with a small screwdriver, with the cover removed.

Construction

The circuit board is located on top of the motor plate and is wired directly to the terminal strip.

Specification

Voltage	: 110 or 220V 50/60 Hz.		
Temperature	: -20°C to +70°C		
Speed	: Model	Min.	Max.
		sec.	sec.
	EL 55	11.5	255
	EL 100	13.5	298
	EL 150	17.0	383
	EL 200	25.5	574
	EL 350	41.5	936
	EL 500	48.5	1085
	EL 800	48.5	1085
	EL 1200	48.5	1085
	EL 1600	48.5	1085
	EL 2500	53.0	1191

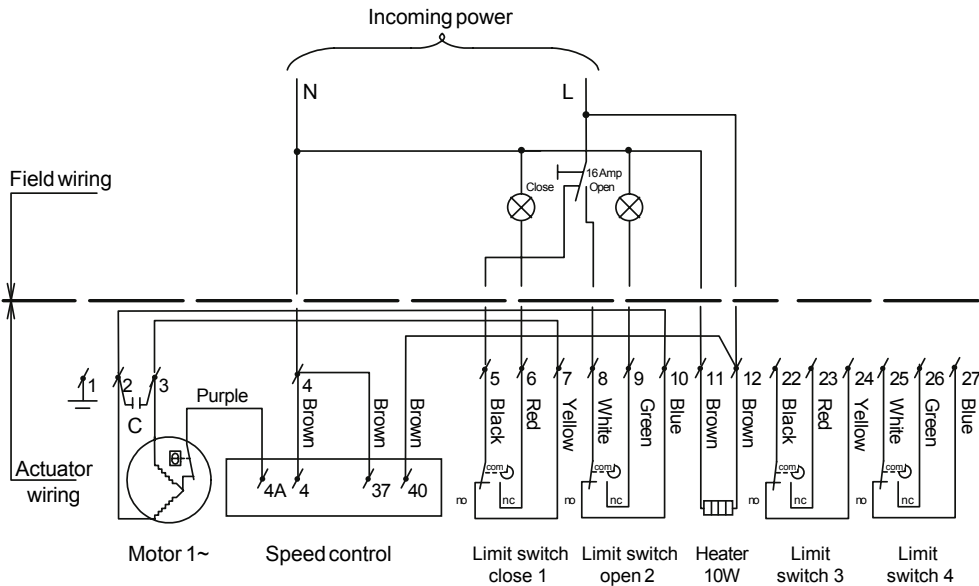

Identification

- Factory Option : Add "+ SC" to the basic actuator size
: eg. EL100 220/50 + SC
- Kit Option : Actuator size is added to: "Kit, SC"
: eg. Kit, SC/EL100 220/50

- Note**
- 1) When supplied as a kit option, all the components as shown are included, together with an instruction sheet
 - 2) Wiring diagram is shown with actuator in mid position
 - 3) Wiring diagram for EL55 220V/50Hz + SC



www.El-O-matic.com

Copyright © Emerson Process Management. The information in this document is subject to change without notice.

Updated data sheets can be obtained from our website www.El-O-matic.com or from your nearest Valve Automation Center **USA**: +1 813 319 0266 **Europe**: +31 74 256 10 10 **Asia-Pacific**: +65 6501 4600



EMERSON
Process Management