

# Data sheet

Sheet No.: A5.105.1 Rev.A  
Date: November 2009

## DIMENSIONS AND TECHNICAL DETAILS - ELECTRIC ACTUATOR

EL Exd

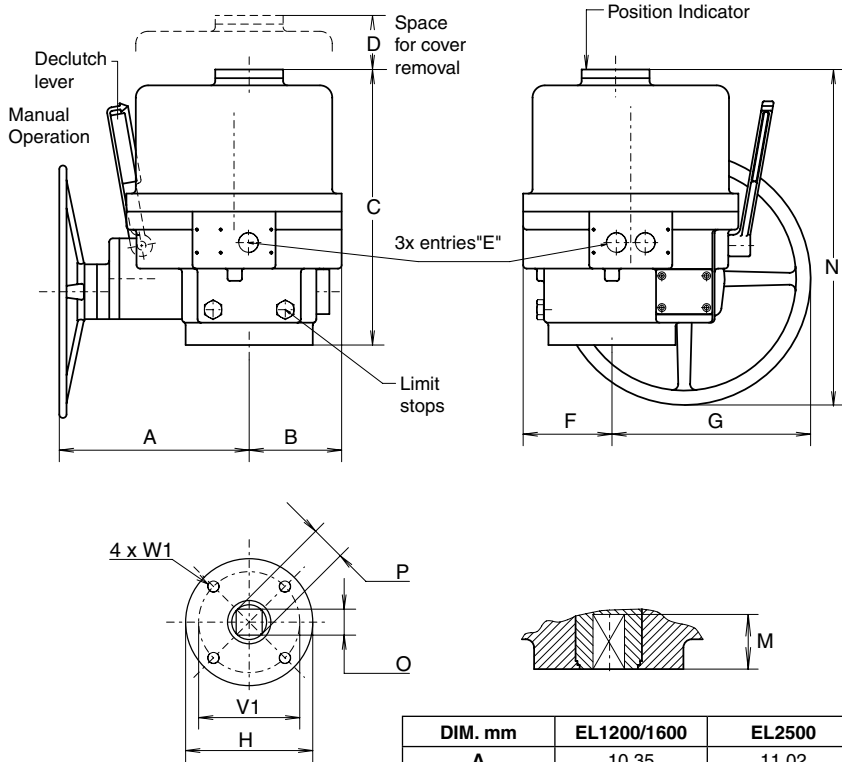

DIM. mm	EL1200/1600	EL2500
A	10.35	11.02
B	5.04	8.66
C	14.88	19.09
D	4.33	5.12
E	3x3/4"NPT	3x3/4"NPT
F	4.84	5.04
G	10.28	12.76
H	6.93	8.27
M	2.44	2.91
N	18.50	26.77
O max.	1.417	1.811
O min.	1.424	1.817
P	1.898	2.370
V1	5.512	6.496
W1	5/8"-11 x 1	3/4"-10 x 1.4

### Description

Type EL actuators use worm and wormwheel reduction gearing to provide tight positioning control and the self locking feature necessary for controlling larger valves, particularly butterfly types.

The explosionproof housing consists of two aluminum castings, this contains the drive motor and worm gear assembly, together with the anti-condensation heater and main terminal strip.

EL actuators take the full range of control options, they have handwheel geared manual overrides, mechanical end position stops and torque switches on all the larger sizes. Visual position indication is by a window in the top cover.

### General Specification

- Nominal Rotation : 90° - factory set to ±3°  
: Adjustable by limit switches 10° to 320°
- Explosion proof : II 2 G EEx d IIB T4  
: suitable for ATEX Zones 1, 2 (gas)
- Certificatenr. : KEMA 03ATEX2156X
- Enclosure : IP67 (Optional: IP68)
- Temperature : -20°C to +70°C
- Connections : By 12 and 16 point internal terminal strip
- Finish : Two component polyurethane coating
- Life : 50,000 operations minimum
- Heater : 10 Watt
- Voltages :  
- Single phase : 110-130V 50Hz or 60Hz  
: 220-240V 50Hz or 240-280V 60Hz  
- Three phase : 380-415V 50Hz or 415-460V 60Hz
- Other voltages : On request
- Stall protection : By torque switches and motor thermostat
- Identification : Example: EL1200 Exd

**Minimum customer switch or contactor rating 16Amp.**

Performance		EL1200/1600	EL2500
Torque (Nm)	Break	10621/14161	22127
	Run	3717/4717	7744
Speed (Sec.)	50Hz	25.5	28
Current (A) (Max.)	220V AC	7	27
	380 3ph	2.8	9
Power (W)	220V AC	450	792
		4x16A	4x16A
Torque SPDT at 110/240VAC		2x16A	2x16A
Weight (Kg.)		81.5	165
Duty rating		30%	30%

**EL-O-MATIC™**

www.El-O-matic.com

Copyright © Emerson Process Management. The information in this document is subject to change without notice.

Updated data sheets can be obtained from our website [www.El-O-Matic.com](http://www.El-O-Matic.com) or from your nearest Valve Automation Center **USA:** +1 813 319 0266 **Europe:** +31 74 256 10 10 **Asia-Pacific:** +65 6501 4600



**EMERSON™**  
Process Management