

# Data sheet

Sheet No.: A5.301 Rev. A  
Date: November 2009

## ELQ ACTUATOR WITH TWO EXTRA SWITCHES

Q-XS2

### Description

This ELQ electric actuator option provides two extra single pole double throw limit switches for indicating the fully open and the fully closed actuator position. This option can be used when higher voltages than 24V are used for position indication, for instance 110V or 220V.

This option makes use of V3 type switches. As a variation of this option 3-wire proximity switches (V3 type) can be provided.

### Construction

The kit is mounted on top of the mainboard (1). The switches are operated by their own cams (2) which are driven by the indicator shaft (3). The two switches on the top are the standard switches, the switches on bottom are the extra switches.

The ELQ-actuator has a yellow 6 pole connector (4) to connect the extra limit switches to the terminals in the terminal compartment. The connectors (5) for motor switches and standard limit switches can be plugged into the sockets on the mainboard.

### Specifications

	Limit switches	Extra limit switches
Type	: V3, mechanical	V3, mechanical
Voltage	: max. 30 VAC or DC	max. 30 VAC or DC
Current	: 500mA at 30 VDC/VAC	500mA at 30VDC/VAC
Temperature	: -4.0° to +158°F	-4.0°F to +158°F

### Identification

Factory option	: Add "+ Q-XS2" to the basic actuator size e.g. ELQ100 + Q-XS2
Kit option	: Actuator size is added to: "Kit Q-XS2" e.g. Kit Q-XS2/ ELQ100

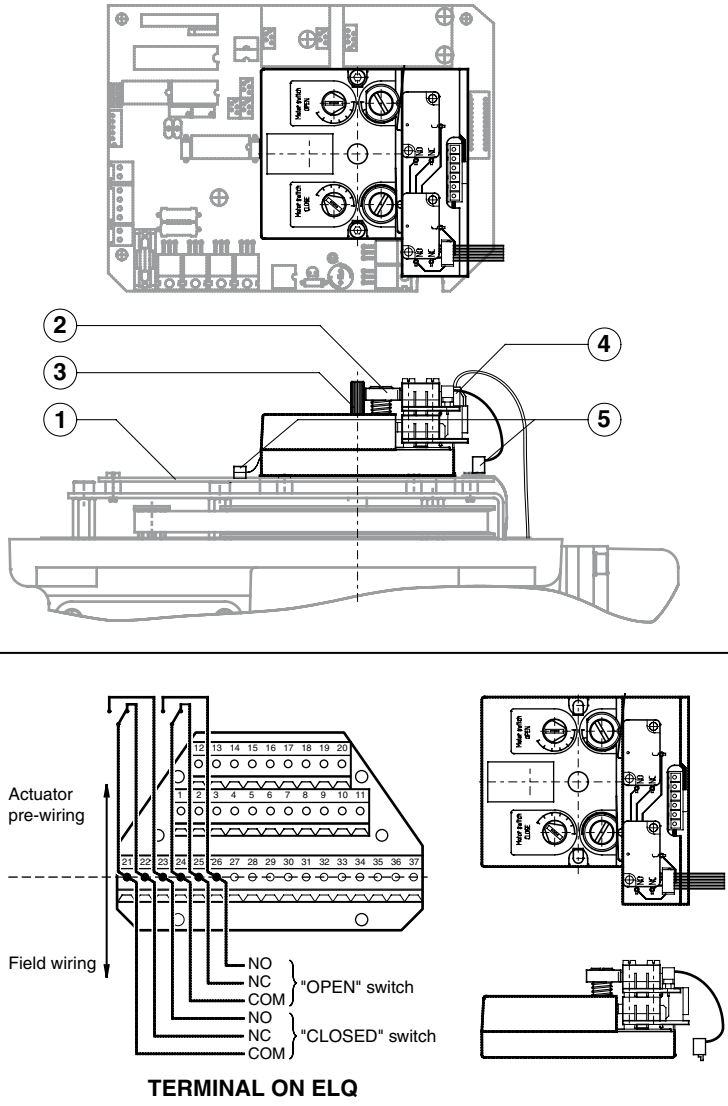

**EL-O-MATIC™**

www.El-O-matic.com

Copyright © Emerson Process Management. The information in this document is subject to change without notice.

Updated data sheets can be obtained from our website [www.El-O-Matic.com](http://www.El-O-Matic.com) or from your nearest Valve Automation Center **USA:** +1 813 319 0266 **Europe:** +31 74 256 10 10 **Asia-Pacific:** +65 6501 4600

**EMERSON™**  
Process Management